

# Optibreak

A high-performance, high-quality range of ACBs with a host of features and accessories built to give you the advantage.



Frame 1 Draw-Out



Frame 2 Fixed



Frame 2 Draw-Out



LSIg  
Trip Unit

## Complete range till 6300A

Frame	ICU (kA)	630	800	1000	1250	1600	2000	2500	3200	4000	5000*	6300*	
2000	$\frac{50}{65}$	Available						Available					
3200	$\frac{50}{65}$	Available						Available		Available			
4000	$\frac{65}{85}$	Available						Available		Available		Available	

## Fixed & Draw-Out type



## Nomenclature





— optibreak —

50/60 Hz	Ue [V]
	415

I1-M-3P  
**820211**  
Ie=2000A

Icw(1s)=65kA  
Icm(415V)=143kA  
Uimp=12kV  
Ui=1000V

IEC/EN 60947-3  
Category AC-23A

**INDOASIAN**



— optibreak —

50/60 Hz	Ue [V]	Icu [kA]
	415	65
	690	40

B1- M-3P  
**820126**  
In=2000A

Icw(1s)=65kA  
Ics=100%Icu  
Uimp=12kV  
Ui=1000V

IEC/EN 60947-2  
Category-B

**INDOASIAN**

Optibreak B2 L 3200A 4P

Optibreak



No. of poles: 3P, 4P

Rated current: 630A, 800A, 1000A, 1250A, 1600A & 2000A, 2500A & 3200A

Breaking capacity - L for 50kA Ics=Icu=Icw(1s)

- M for 65kA Ics=Icu=Icw(1s)

- H for 85kA Ics=Icu=Icw(1s)

Frame size: ACB - B1 for 2000A & B2 for 3200A

Trip free - I1 for 2000A & I2 for 3200A

Design model of air circuit-breaker

## Two types of releases

LSIG



LSI



# Settings



LSI protection



LSIG protection

Use the adjustment knob to select the following settings:

- Long delay overload protection:  $I_r$
- Over delay protection operation time:  $t_r$
- Short circuit short delay protection:  $I_{sd}$
- Short delay action time:  $t_{sd}$
- Instantaneous short circuit protection:  $I_i$
- Neutral line protection: N

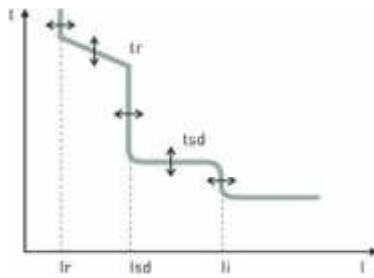

- Long delay overload protection:  $I_r$
- Over delay protection operation time:  $t_r$
- Short circuit short delay protection:  $I_{sd}$
- Short delay action time:  $t_{sd}$
- Instantaneous short circuit protection:  $I_i$
- Ground-fault protection:  $I_g$
- Ground-fault protection time:  $t_g$
- Neutral line protection: N

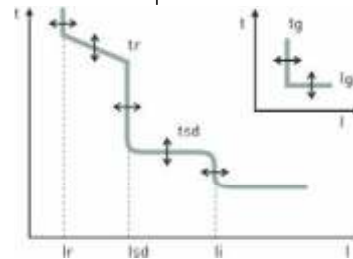

**Overload protection (Long Time setting)**

Setting of current (@12xI<sub>g</sub> 2x6 steps)  
 $I_r = 0,4 \div 1 \times I_n$   
 With 2 switches  
 (0,4 ÷ 0,9, steps of 0,1  
 0,0 ÷ 0,1, steps of 0,02)

Example:

$$I_r = 0.4 + 0.06 = 0.46 I_n$$

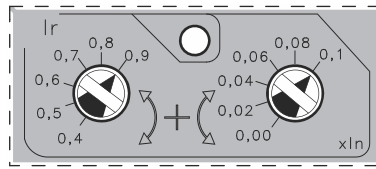

Setting of time delay (@6I<sub>r</sub>)  
 (4+4 steps)  
 $t_r = 5-10-20-30s$  (MEM ON)  
 $t_r = 30-20-10-5s$  (MEM OFF)

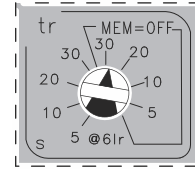

**Short circuit protection**

Setting of current (9 steps)  
 $I_{sd} = 1.5-2-2.5$   
 $3-4-5-6-8-10 \times I_r$   
 $I_{sd} = 1.5-2-2.5$   
 $3-4-5-6-8-10 \times I_n$

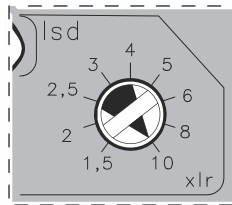

Setting of time delay (5+4 steps)  
 $T_{sd} = 0-0.1-0.2-0.5-1s$  (t=const)  
 $T_{sd} = 1-0.5-0.2-0.1s$  (I<sup>2</sup>t=const)

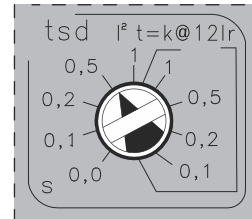

**Instantaneous short circuit protection**

Setting of current (9 steps)  
 $I_i = 2-3-4-6-8$   
 $10-12-15 \times I_n - I_{cw}$

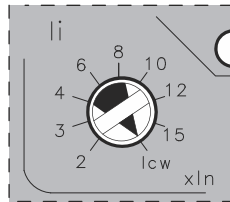

**Ground-fault protection**

Setting of current (9 steps)  $I_g = 0.2-0.3-0.4-0.5-0.6-0.7-0.8-1 \times I_n$  - OFF  
 Setting of time delay (@12x I<sub>g</sub>) (4+4 steps)  
 $t_g = 0.1-0.2-0.5-1s$  (t=const)  
 $t_g = 1-0.5-0.2-0.1s$  (I<sup>2</sup>t= const)

**Neutral protection**

Setting of current (3 steps)  
 $N = OFF - 50\% - 100\%$

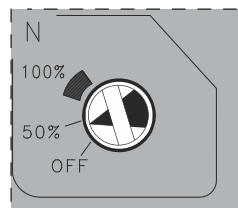

**Protection against over temperature**  
 (not adjustable)  
 $t > 95^\circ C$

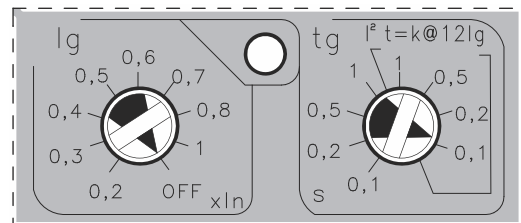

## Adjustable range $I_{cs}=100\% I_{cu}$

ICU		ICS		ICW
50 kA		50 kA		50 kA
65 kA	▶	65 kA	▶	65 kA
85 kA		85 kA		85 kA

ICW = 100%  $I_{cs}$  for 1 Sec

## Sliding shutters

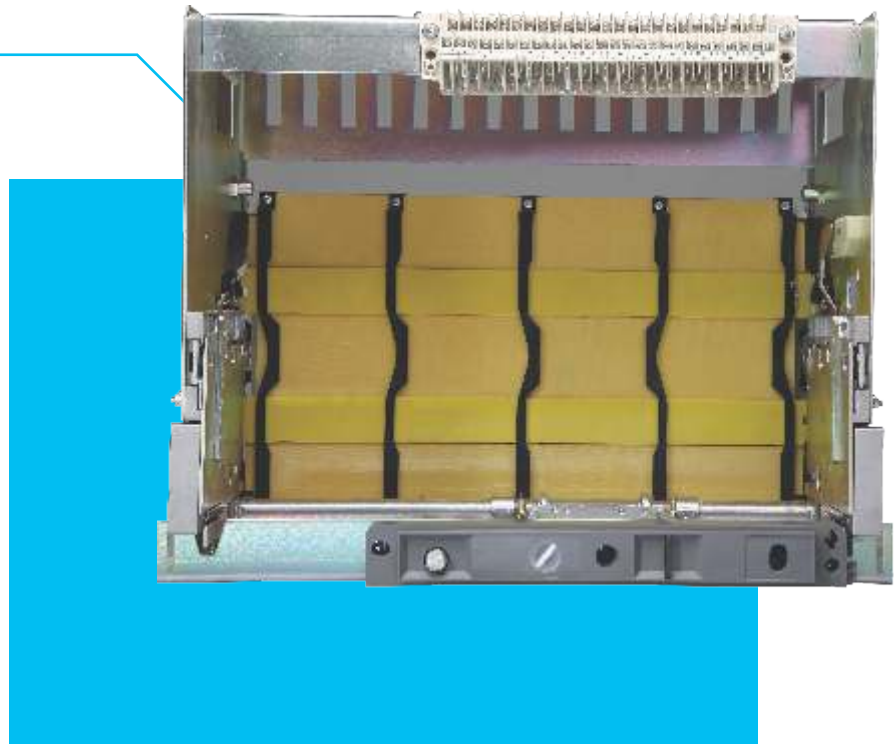

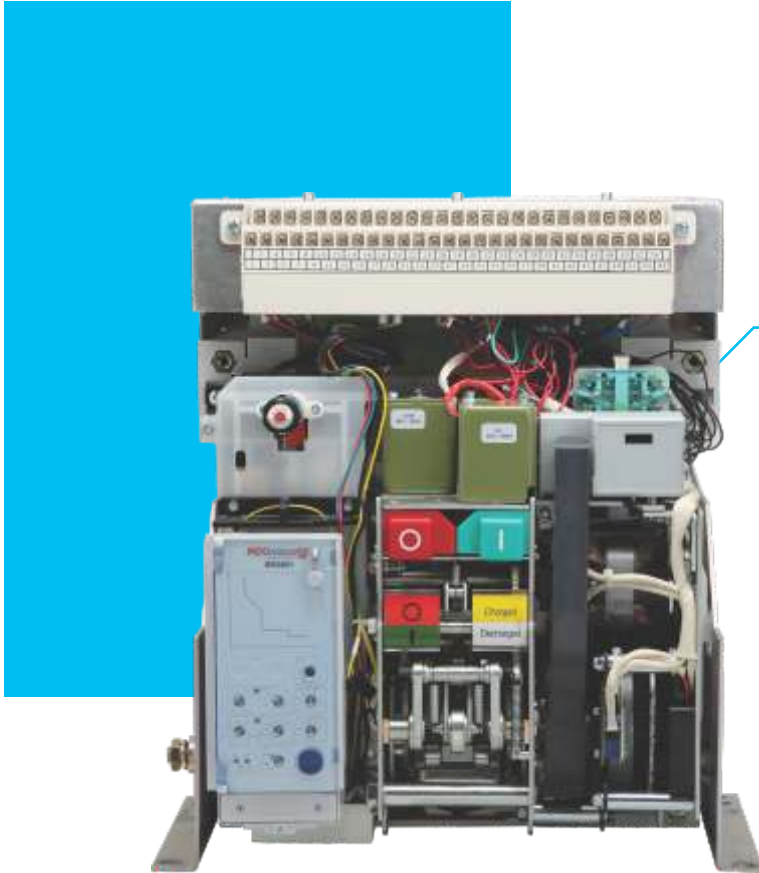

Front-mounted accessories

Wide rear terminals for connections





**Dedicated mounting space for accessories**

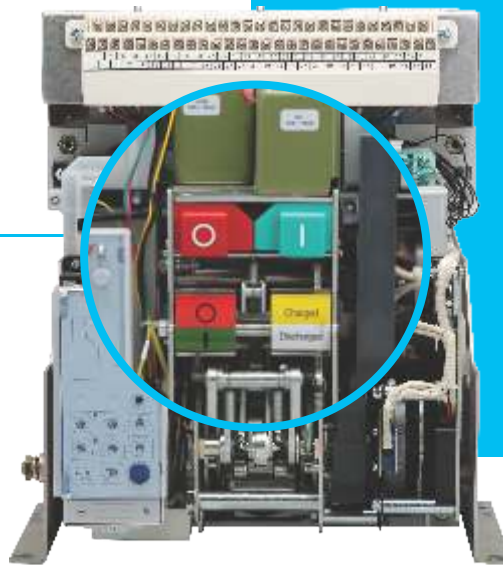

**Inbuilt phase barriers**

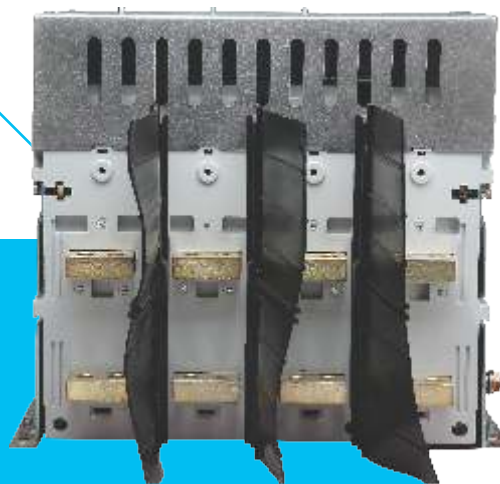

Front accessory connections  
for easy and quick wiring



Front facia indication for  
ON/OFF and Spring status

## Inbuilt temperature protection

# Protection against over temperature

(not adjustable)

$t > 95^{\circ}\text{C}$

## Front indication on release

LED 1

LED 2

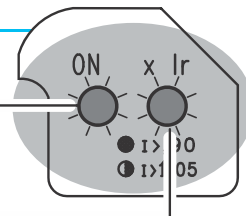

Protection	LED 1	LED 2
Inactive	Switched off	Switched off
Active ( $I \geq 100\text{A}$ or supplied)	Green	Fix Switched off
Active: (overload pre alarm ( $I > 0,9 I_r$ ))	Green Fix	Red Fix
Active: (overload alarm $I > 1,05 I_r$ )	Green Fix	Red Flashing
Active: (overload alarm $I > 1,05 I_r$ )	Green Flashing	Red Flashing

## Complete range of accessories

---

- Power module
- Shunt release
- Auxiliary contact
- Closing release
- UV release
- Motor operator
- Door frame
- Key lock on the Off position
- Phase separator
- Door interlock
- Mechanical interlock lever type
- Dust cover
- Mechanical interlock cable type
- External neutral pole CT

# Optibreak B1 & B2

## General product information

Type Explanation

Example

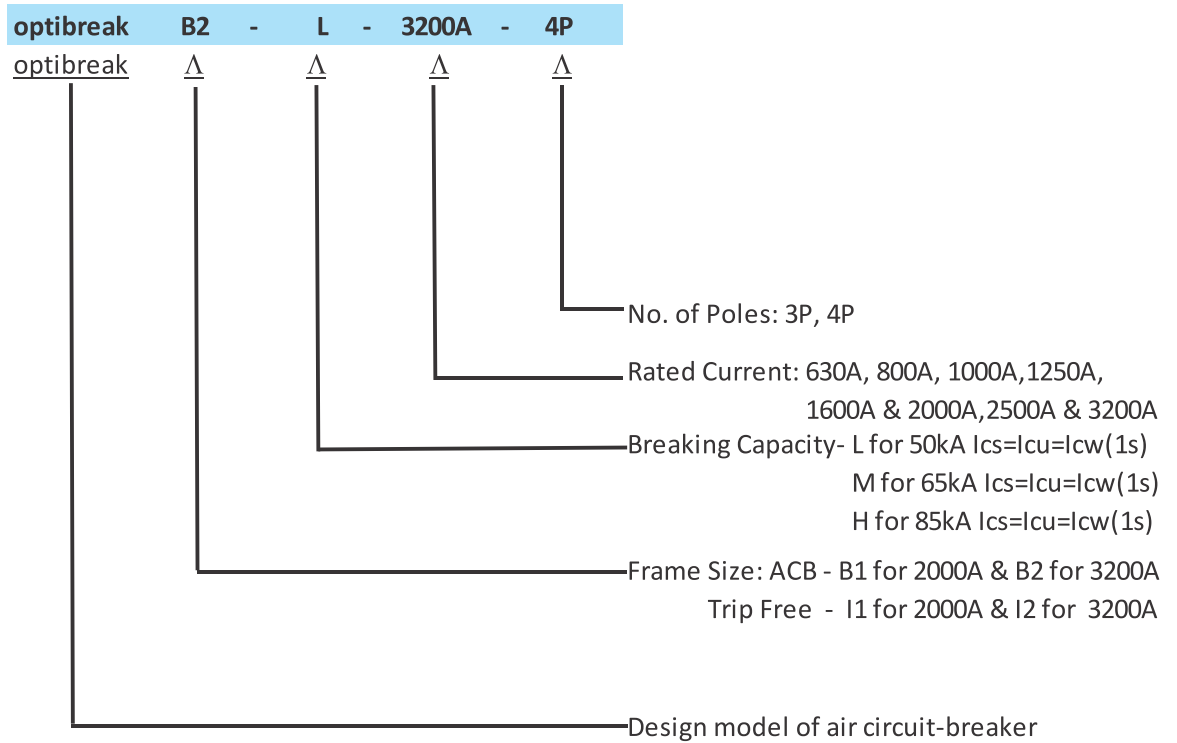

# Optibreak B1 & B2



1. Open / close Indication
2. Charge and Discharge Indicator
3. Release the reset button
4. Laser Nameplate
  - 4a Product Code
  - 4b Frame Rating
  - 4c Selectivity category
  - 4d Standard Compliance
  - 4e Rated current
  - 4f Rated insulation voltage
  - 4g Rated impulse withstand voltage
  - 4h Rated operating voltage
  - 4i Rated ultimate short circuit breaking capacity
  - 4j Rated service short circuit breaking capacity
  - 4k Rated short time withstand current
5. Dust Cover (optional)
6. key Lock (optional) Location(knockout)
7. Pad Lock in Isolate Position
8. Rack in Handle insertion hole
9. Draw out position indicator
10. Rack in handle storage
11. Earthing Terminals
12. Phase barriers
13. Manual Charging Handle
14. ON Button
15. OFF Button

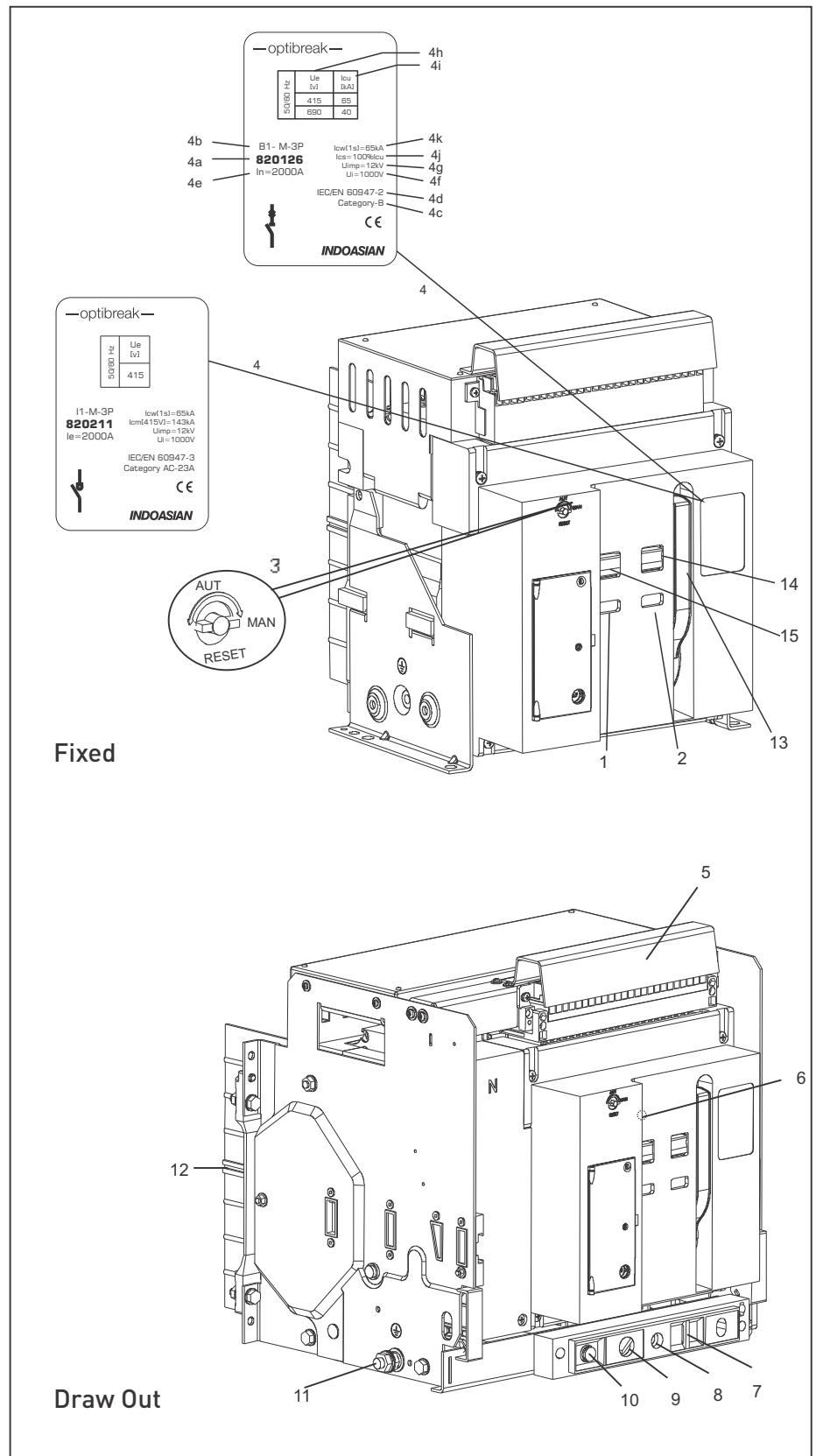

## Product Function and Characteristics: B1 & B2

Air Circuit Breakers		Optibreak B1		Optibreak B2
Frame Inm A		2000		3200
Rated current In A		630 800 1000 1250 1600 2000		2500 3200
Poles		3/4		3/4
Rating of N-Pole		100% In		100% In
Rated Operating voltage Ue		AC 415V/AC 690V		AC 415V/AC 690V
Rated insulation voltage Ui		1000V		1000V
Rated impulse withstand voltage Uimp		12KV		12KV
Pollution Degree		Grade-3		
Mounting	Fixed	■		■
	Drawer	■		■
Rated ultimate short-circuit breaking capacity Icu(kA)		<b>L</b>	<b>M</b>	<b>M</b>
AC 415V 50/60Hz		50	65	65
AC 690V 50/60Hz		40	40	50
Rated Service short-circuit breaking capacity Ics(kA)				
AC 415V 50/60Hz		50	65	65
AC 690V 50/60Hz		40	40	50
Rated short time withstand current Icw (1s)kA				
AC 415V 50/60Hz		50	65	65
AC 690V 50/60Hz		40	40	50
Utilization category		B		B
Protection unit PU	LSI( Ir,li,I <sub>sd</sub> )	■		■
	LSIG( Ir,li,I <sub>sd</sub> ,I <sub>g</sub> )	■		■
Suitable For Isolation		■		■
Standards compliant		IEC 60947-2		
Operating Life	Mechanical life	15000		10000
	Electrical life	8000		5000
Dimensions WxDxH(mm)	Fixed	3P	362x323x402	422x323x402
		4P	457x323x402	537x323x402
	Drawer	3P	375x421x432	435x421x432
		4P	470x421x432	550x421x432
Weight (Kg)	Fixed	3P	41	56
		4P	50	68
	Drawer	3P	71	96
		4P	91	118

## Product Function and Characteristics: B3

Air Circuit Breakers		<b>Optibreak B3</b>	
Frame Inm A		4000	
Rated current In A		3200 & 4000A	
Poles		3/4	
Rating of N-Pole		100% In	
Rated Operating voltage Ue		AC 415V/AC 690V	
Rated insulation voltage Ui		1000V	
Rated impulse withstand voltage Uimp		12KV	
Pollution Degree		Grade-3	
Mounting	Fixed	■	
	Drawer	■	
Rated ultimate short-circuit breaking capacity Icu(kA)		<b>H</b>	
AC 415V 50/60Hz		85	
AC 690V 50/60Hz		65	
Rated Service short-circuit breaking capacity Ics(kA)			
AC 415V 50/60Hz		85	
AC 690V 50/60Hz		65	
Rated short time withstand current Icw (1s)kA			
AC 415V 50/60Hz		85	
AC 690V 50/60Hz		65	
Utilization category		B	
Protection unit PU	LSI( Ir,li,Isd)	■	
	LSIG( Ir,li,Isd,Ig)	■	
Suitable For Isolation		■	
Standards compliant		IEC 60947-2	
Operating Life	Mechanical life	5000	
	Electrical life	2500	
Dimensions WxDxH(mm)	Fixed	3P	419×308×416
		4P	545×308×416
	Drawer	3P	440×407×450
		4P	566×407×450
Weight (Kg)	Fixed	3P	4000A- 66 kg, below- 55kg
		4P	4000A- 80 kg, below- 68kg
	Drawer	3P	4000A- 131 kg, below- 120kg
		4P	4000A- 160 kg, below- 148kg



## Accessories



LSI protection



LSIg protection

Use the adjustment knob to select the following settings:

- Long delay overload protection:  $I_r$
- Over delay protection operation time:  $t_r$
- Short circuit short delay protection:  $I_{sd}$
- Short delay action time:  $t_{sd}$
- Instantaneous short circuit protection:  $I_i$
- Neutral line protection: N

- Long delay overload protection:  $I_r$
- Over delay protection operation time:  $t_r$
- Short circuit short delay protection:  $I_{sd}$
- Short delay action time:  $t_{sd}$
- Instantaneous short circuit protection:  $I_i$
- Ground-fault protection :  $I_g$
- Ground-fault protection time:  $t_g$
- Neutral line protection: N

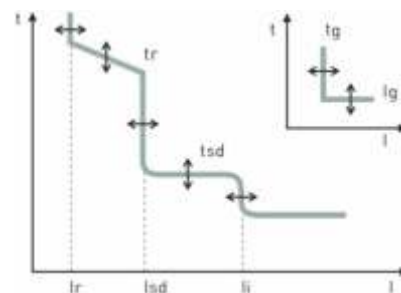
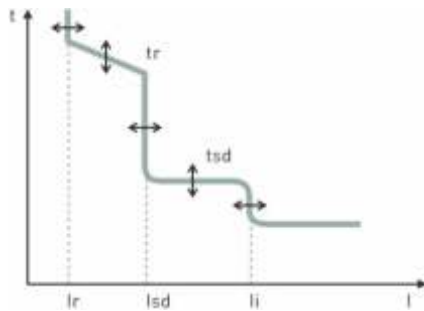

Cat. Ref.

820401 LSI protection  
 $I_r=0.4-1 I_n$  Adjustable  
 $t_r=5-10-20-30s$  Adjustable(6I<sub>r</sub>)  
 $I_{sd}=1.5-2-2.5-3-4-5-6-8-10I_r$  Adjustable  
 $t_{sd}=0-0.1-0.2-0.5-1s$  Adjustable  
 $I_i=2-3-4-6-8-10-12-15I_n-I_{cw}$  Adjustable

Cat. Ref.

820402 LSIg protection  
 $I_r=0.4-1 I_n$  Adjustable  
 $t_r=5-10-20-30s$  Adjustable(6I<sub>r</sub>)  
 $I_{sd}=1.5-2-2.5-3-4-5-6-8-10I_r$  Adjustable  
 $t_{sd}=0-0.1-0.2-0.5-1s$  Adjustable  
 $I_i=2-3-4-6-8-10-12-15I_n-I_{cw}$  Adjustable  
 $I_g=0.2-0.3-0.4-0.5-0.6-0.7-0.8-1I_n$  Adjustable / can be turned off  
 $t_g=0.1-0.2-0.5-1s$  Adjustable

# Protection Unit (PU)- Tripping Curve

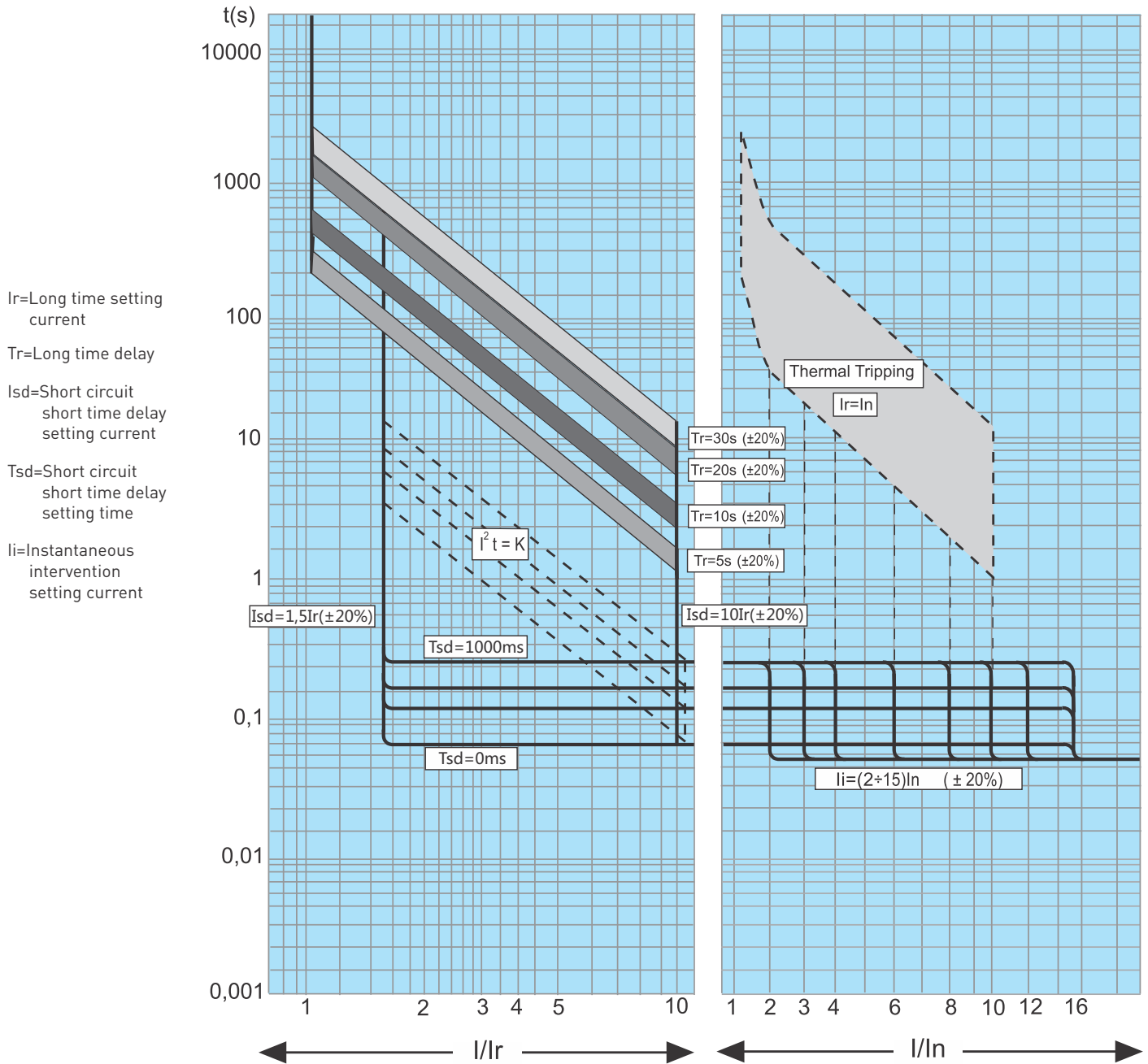

If short-circuit current is higher than low value or  $I_i$  is setted at low position, tripping time is equal to 30ms.

## Protection Unit (PU)- Tripping Curve

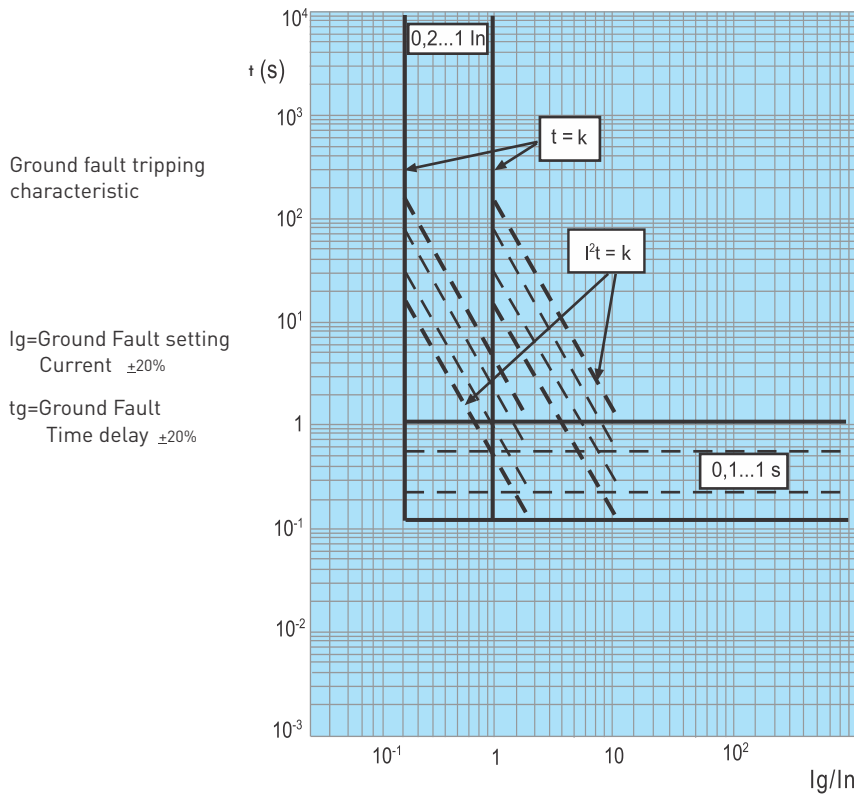

## Protection Unit (PU)- Energy Curve

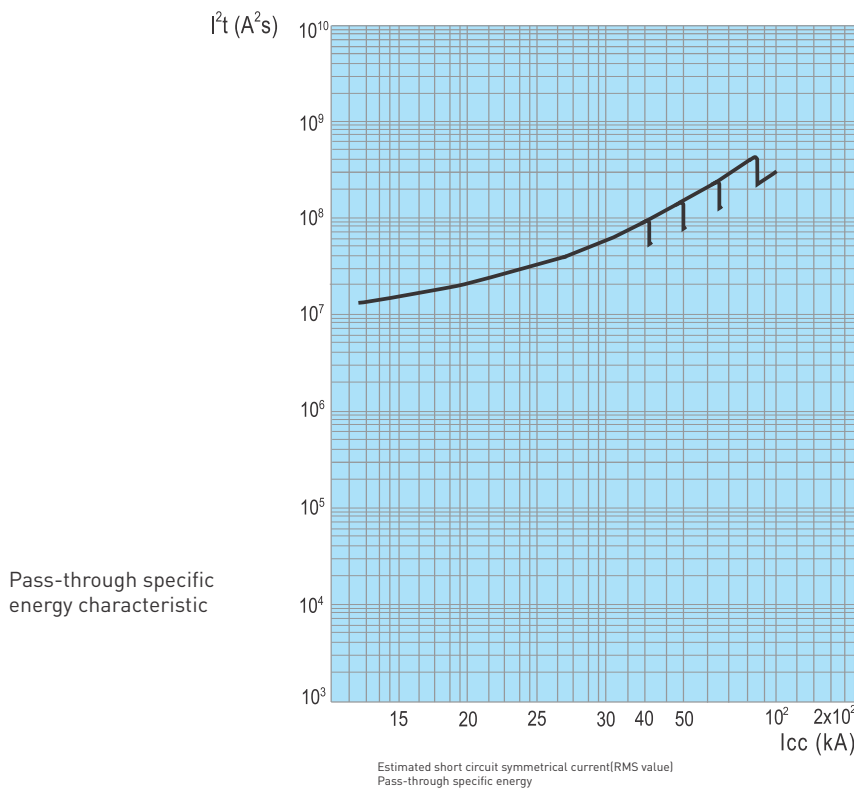

## Details of Accessories

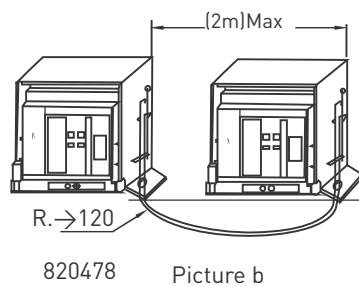
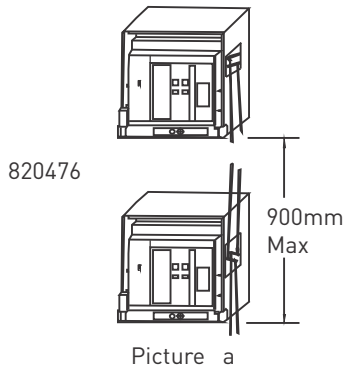

### ■ Mechanical interlock

The components should be installed on the right side plate of the draw-out breaker. There are two type of component: the lever type and the wirerope type. The lever type is useable for the vertical installation referring to the picture a. The wirerope type is usable for the vertical or horizontal installation referring to picture b.

When one breaker is closed, the another breaker can not be closed. The components should be installed by the customer and the type of the components should be specified.

Delivery method: optional (Customer to mention references during order booking)

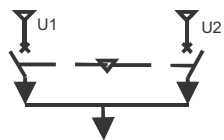

number of the power	U1	U2
the probably case of the breakers interlocking	C	O
	O	C
	O	O

### ■ Mechanical interlock type

two breakers refer to the left diagram  
three breakers refer to the below diagram

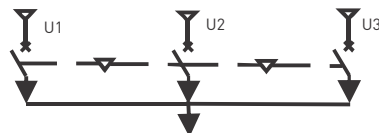

number of the power	U1	U2	U3
the probably case of the breakers interlocking	C	O	O
	O	C	O
	C	O	C
	O	O	O

# Wiring Diagram

- 1 & 2 - PU'S Power supply input 12V DC Regulated through 820491 or 820492
  - 3,4,5 - Fault Signal contact output (4=Common, 3=NC & 5=NO), Capacity: AC250V 16A.
  - 6,7 - NO Aux Contact for ACB close indication, Capacity: AC250V 16A.
  - 8,9 - NC Aux Contact for ACB open indication, Capacity: AC250V 16A.
  - 18,19,20 - Not in Use.
  - 23 & 24 - 3P ACB, external N phase Current Transformer port. (optional)
  - 27 & 28 - Undervoltage release connection. (optional)
  - 29,30 - Shunt Release connection. (optional)
  - 31,32 - Closing Release connection. (optional)
  - 33,34 - Motor Charging connection. (optional) (Advance charging)
  - 34,35 - Motor charging indicator.
  - 36,51 - 6 NO/NC auxiliary contact for the Draw-out ACB. (40 to 51 change over contact)
  - 36,55 - 6 NO/NC auxiliary contact for the Fixed ACB. (All are potential free contact)
- 
- SB1 - Shunt Push Button (arranged by customer)
  - SB2 - UVR Push Button (arranged by customer)
  - SB3 - Closing Coil Push Button (arranged by customer)
  - SB4 - Motor Push Button (arranged by customer)
  - SA - Motor Limit switch
  - XT - Secondary isolating Contact circuit
  - J - Relay normally open remote control circuit breaker
  - F - Shunt release
  - X - Closing coil
  - Q - Undervoltage (instantaneous or delay) release
  - W - Breaker auxiliary contacts, 6NO + 6NC
  - FU - Fuse
  - M - Charging Motor
  - Z - Protection Unit (Intelligent controller).

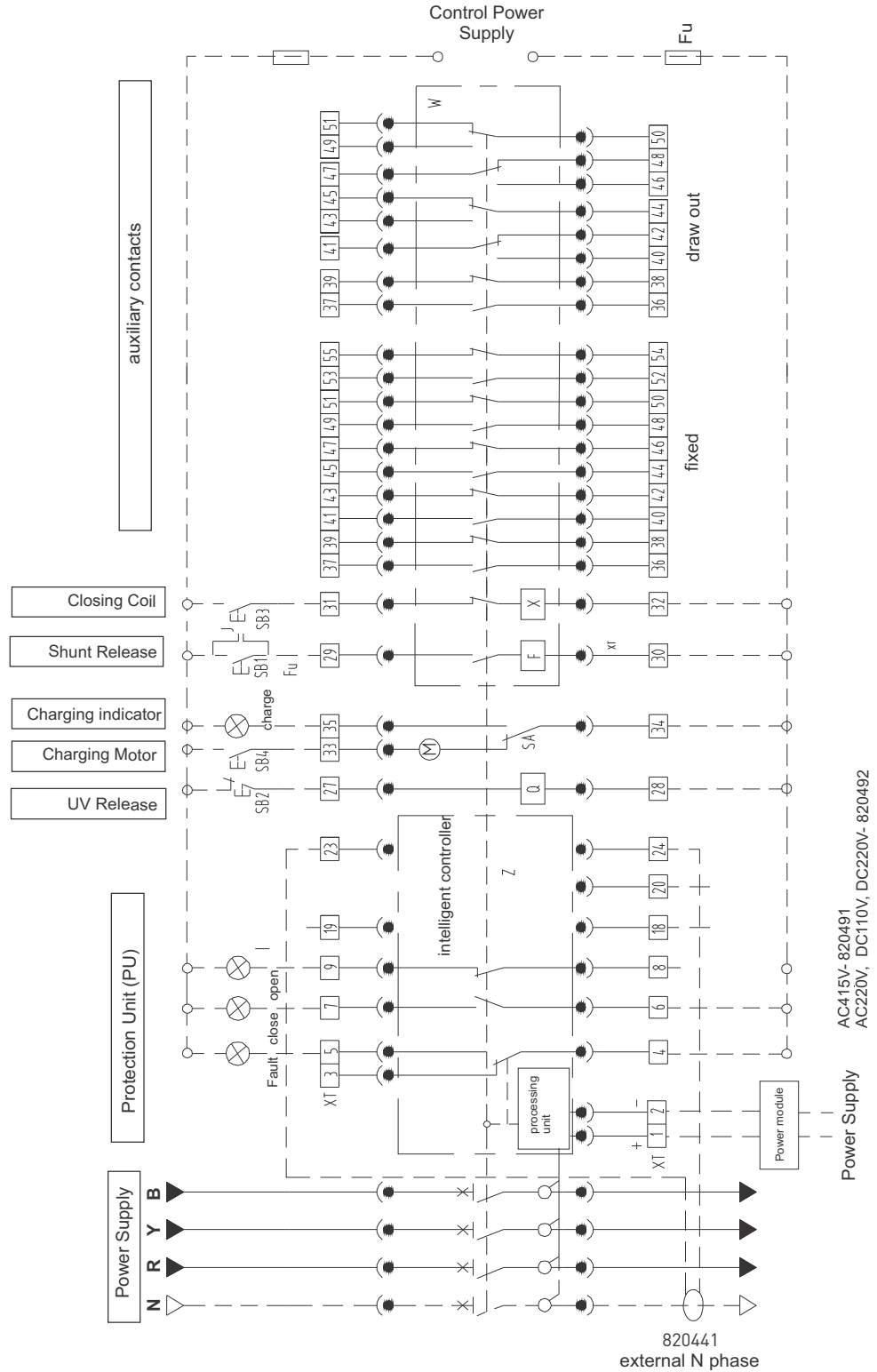

**Note**

1. If Voltage Q, F X M & PU is different, connect separate supply
2. Dash line wiring diagram to be done by user.

## Dimensions & Mounting

### ■ Optibreak B1/I1 - Fixed Type

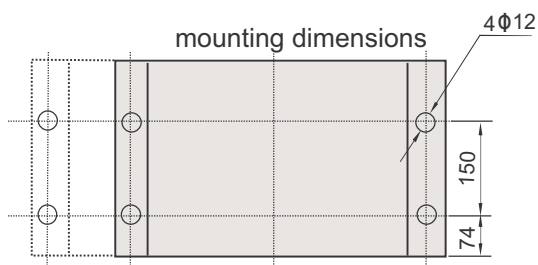
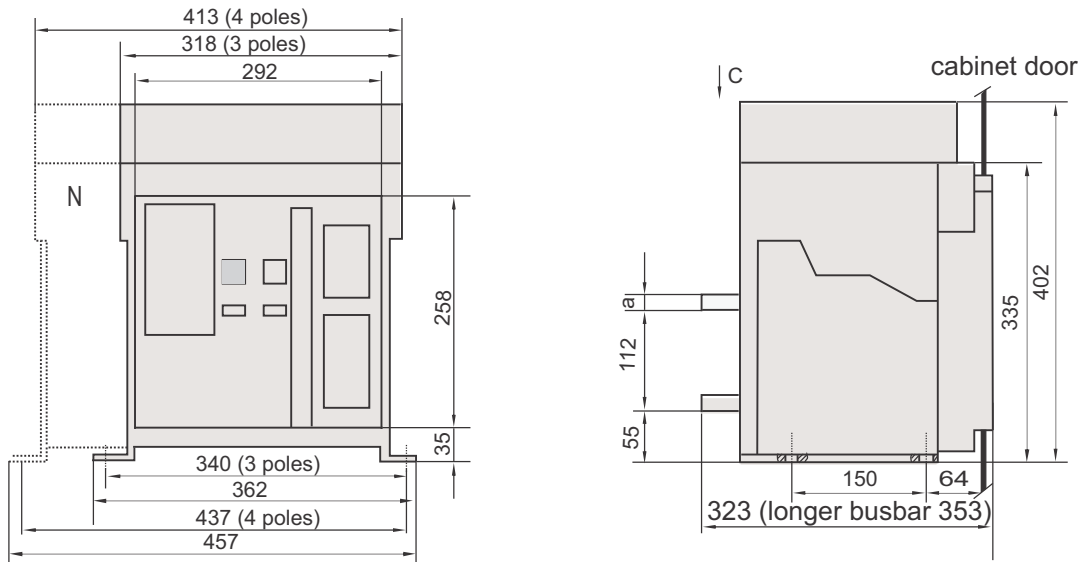

mm	
In(A)	a
630-1000	10
1250-2000	20

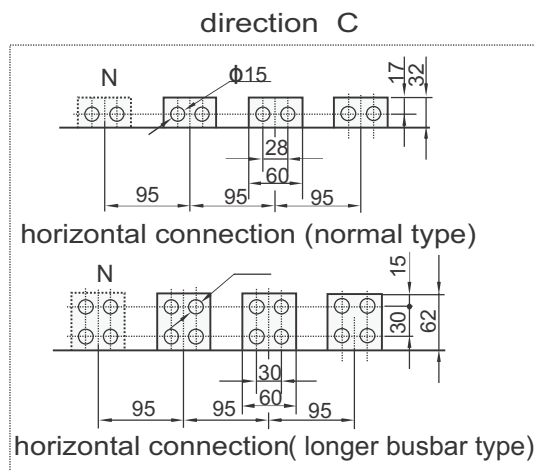

## Dimensions & Mounting

### ■ Optibreak B2/I2 - Fixed Type

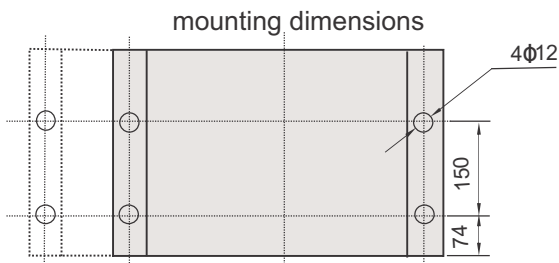
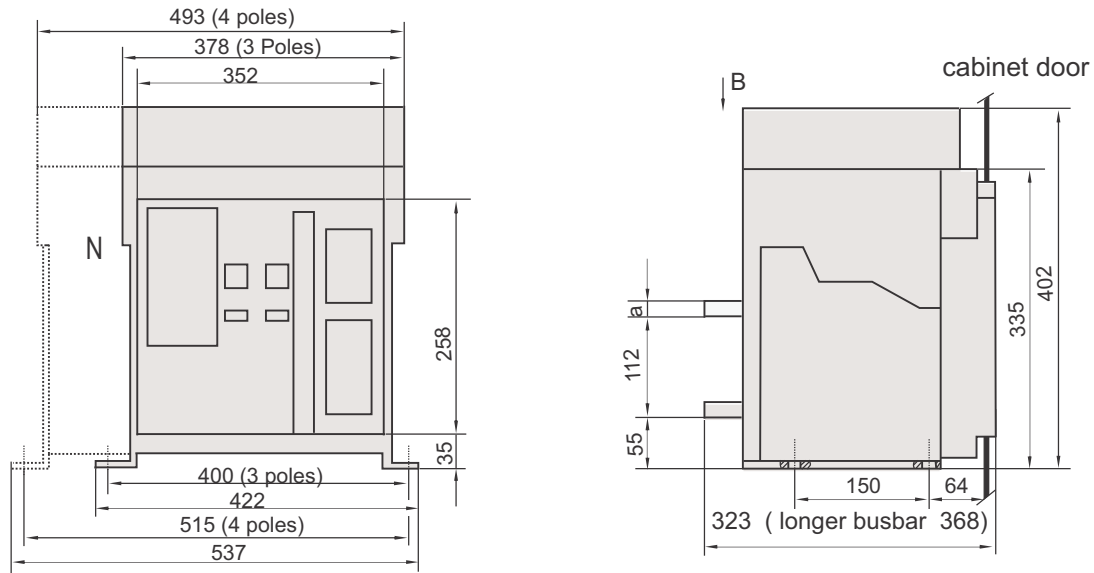

In(A)	a
2500-3200	30

direction B

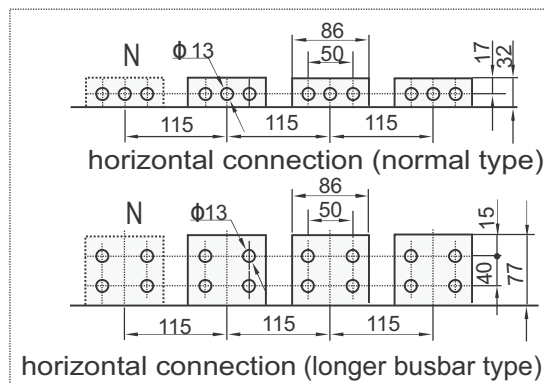

## Dimensions & Mounting

### ■ Optibreak B1/I1 - Draw-out Type

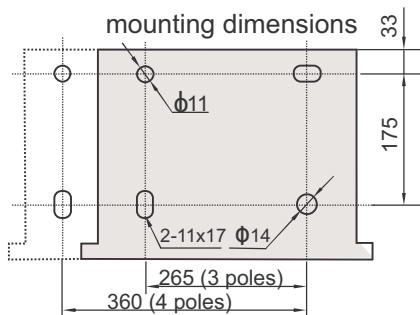
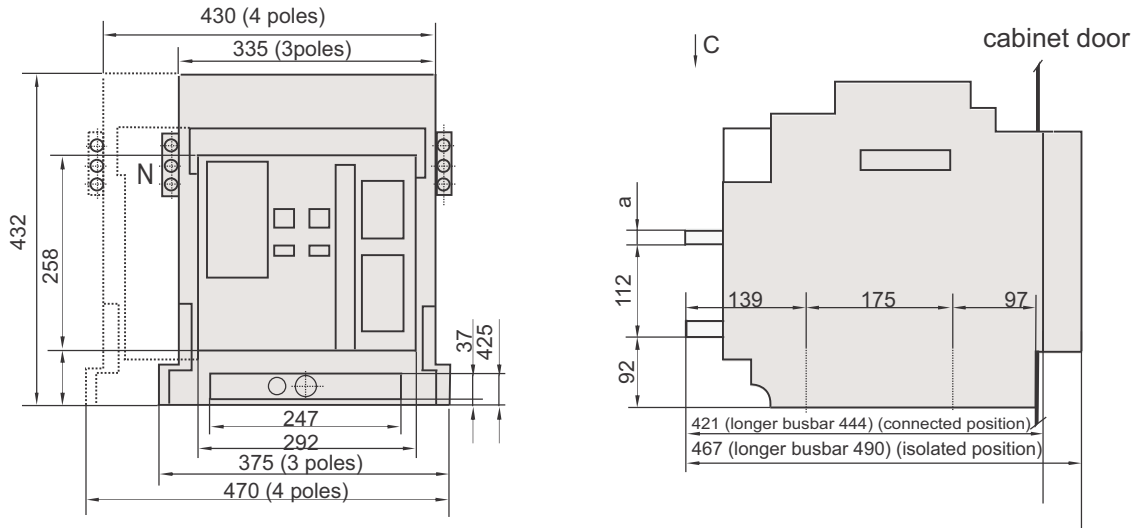

In(A)	mm
630-1000	10
1250-2000	20

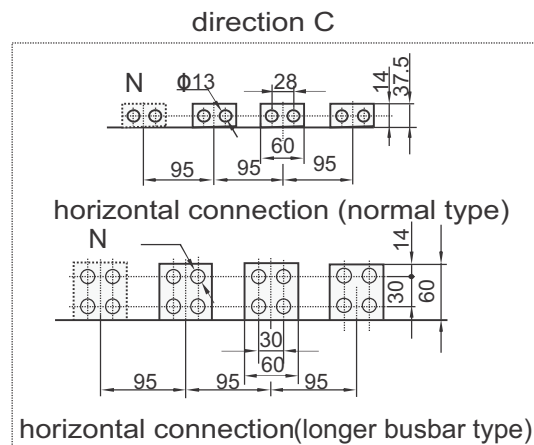



## Dimensions & Mounting

### ■ Optibreak B2/I2 - Draw-out Type

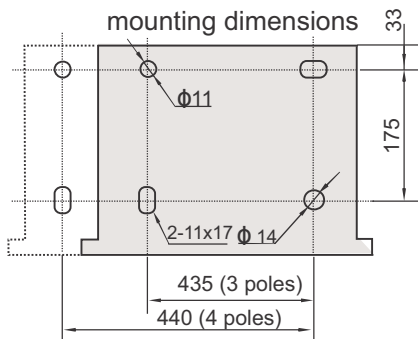
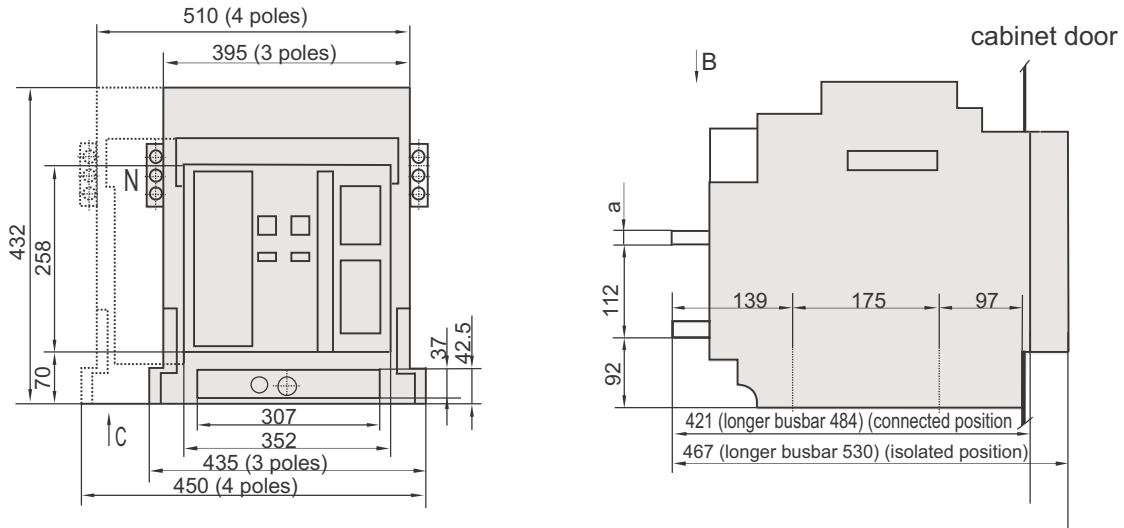

In(A)	a
2500-3200	30

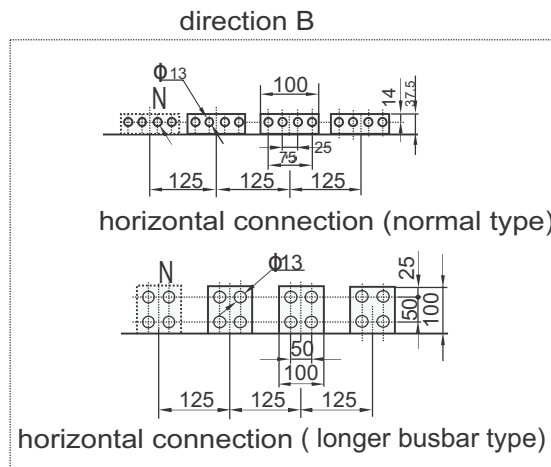

## Dimensions & Mounting

### ■ Door frame dimensions

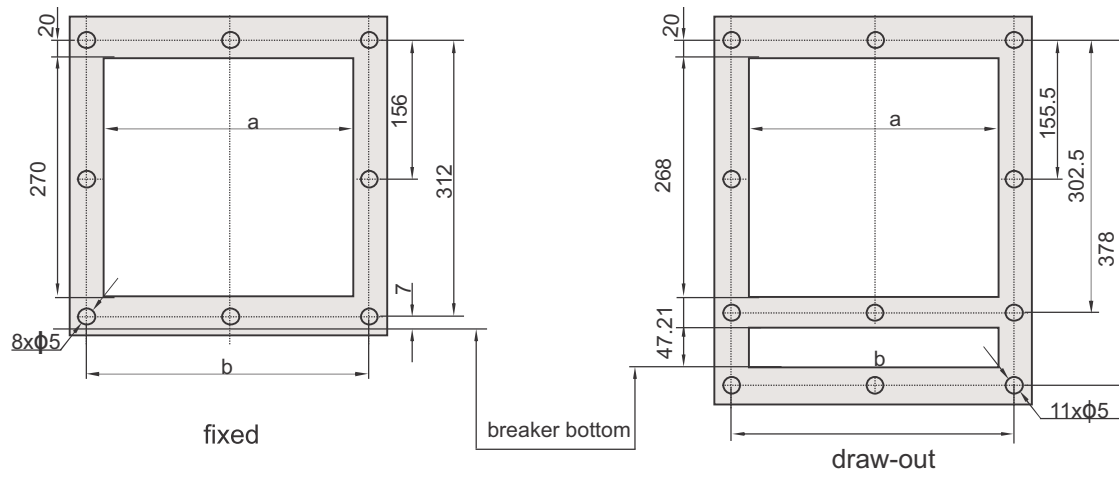

type	a	b
B1/ I1	301	302
B2/ I2	363	405

## Air Circuit Breaker

	Type	Breaking capacity	Frame	Rating	3P	4P
	Fixed	50kA	B1	630	820001	820011
	Fixed	50kA	B1	800	820002	820012
	Fixed	50kA	B1	1000	820003	820013
	Fixed	50kA	B1	1250	820004	820014
	Fixed	50kA	B1	1600	820005	820015
	Fixed	50kA	B1	2000	820006	820016
	Fixed	50kA	B2	2500	820007	820017

	Type	Breaking capacity	Frame	Rating	3P	4P
	D/O	50kA	B1	630	820101	820111
	D/O	50kA	B1	800	820102	820112
	D/O	50kA	B1	1000	820103	820113
	D/O	50kA	B1	1250	820104	820114
	D/O	50kA	B1	1600	820105	820115
	D/O	50kA	B1	2000	820106	820116
	D/O	50kA	B2	2500	820107	820117

	Type	Breaking capacity	Frame	Rating	3P	4P
	Fixed	65kA	B1	630	820021	820031
	Fixed	65kA	B1	800	820022	820032
	Fixed	65kA	B1	1000	820023	820033
	Fixed	65kA	B1	1250	820024	820034
	Fixed	65kA	B1	1600	820025	820035
	Fixed	65kA	B1	2000	820026	820036
	Fixed	65kA	B2	2500	820027	820037
	Fixed	65kA	B2	3200	820051	820061
	Fixed	65kA	B3	4000	820052	820062

## Air Circuit Breaker

	Type	Breaking capacity	Frame	Rating	3P	4P
	D/O	65kA	B1	630	820121	820131
	D/O	65kA	B1	800	820122	820132
	D/O	65kA	B1	1000	820123	820133
	D/O	65kA	B1	1250	820124	820134
	D/O	65kA	B1	1600	820125	820135
	D/O	65kA	B1	2000	820126	820136
	D/O	65kA	B2	2500	820127	820137
	D/O	65kA	B2	3200	820151	820161
	D/O	65kA	B3	4000	820152	820162

	Type	Breaking capacity	Frame	Rating	3P	4P
	Fixed	85kA	B3	3200	820071	820073
Fixed	85kA	B3	4000	820072	820074	

	Type	Breaking capacity	Frame	Rating	3P	4P
	D/O	85kA	B3	3200	820171	820173
D/O	85kA	B3	4000	820172	820174	

## Trip Free Switch

Type	Breaking capacity	Frame	Rating	3P	4P
Fixed	65kA	I1	1000	820201	820205
Fixed	65kA	I1	1250	820202	820206
Fixed	65kA	I1	1600	820203	820207
Fixed	65kA	I1	2000	820211	820213
Fixed	65kA	I2	2500	820212	820214
Fixed	85kA	I3	3200	820215	820217
Fixed	85kA	I3	4000	820216	820218

Type	Breaking capacity	Frame	Rating	3P	4P
D/O	65kA	I1	1000	820301	820305
D/O	65kA	I1	1250	820302	820306
D/O	65kA	I1	1600	820303	820307
D/O	65kA	I1	2000	820311	820313
D/O	65kA	I2	2500	820312	820314
D/O	85kA	I3	3200	820315	820317
D/O	85kA	I3	4000	820316	820318

## Accessories

Product	Frame	Cat Ref.
Release	LSI	820401
Release	LSIg	820402

Product	Frame	Cat Ref.
Auxiliary contact	-	820411

## Accessories

	Product	Frame	Cat Ref.
	Shunt trip 230 V AC	-	820412
	Shunt trip 415 V AC	-	820413
	Shunt trip 110 V DC	-	820414
	Shunt trip 220 V DC	-	820415

	Product	Frame	Cat Ref.
	Undervoltage 230VAC	B1, B2 & B3	820417
	Undervoltage 415VAC	B1, B2 & B3	820419
	Undervoltage 230VAC(0.3 ~ 5s)	B1, B2 & B3	820421
	Undervoltage 415VAC(0.3 ~ 5s)	B1, B2 & B3	820423

	Product	Frame	Cat Ref.
	Closing coil 230 V AC	-	820424
	Closing coil 415 V AC	-	820425
	Closing coil 110 V DC	-	820426
	Closing coil 220 V DC	-	820427

	Product	Frame	Cat Ref.
	Motor Operator 230VAC/220VDC	B1	820428
	Motor Operator 415VAC	B1	820429
	Motor Operator 110VDC	B1	820430

	Product	Frame	Cat Ref.
	Motor Operator 230VAC/220VDC	B2 & B3	820431
	Motor Operator 415VAC	B2 & B3	820432
	Motor Operator 110VDC	B2 & B3	820433

## Accessories

	Product	Frame	Cat Ref.
	Ext Neutral CT B1& B2	-	820441

	Product	Frame	Cat Ref.
	Vertical terminal 3P till 1000A	-	820456
	Vertical terminal 4P till 1000A	-	820457
	Vertical terminal 3P till 2000A	-	820458
	Vertical terminal 4P till 2000A	-	820459
	Vertical terminal 3P 3200A Fixed	-	820460
	Vertical terminal 4P 3200A Fixed	-	820462
	Vertical terminal 3P 3200A D/O	-	20461
	Vertical terminal 4P 3200A D/O	-	820463

	Product	Frame	Cat Ref.
	Phase Seperator3P Fixed	-	820471
	Phase Seperator3P DO	-	820472
	Phase Seperator4P Fixed	-	820473
	Phase Seperator4P DO	-	820474

	Product	Frame	Cat Ref.
	MIL- LeverFixed	-	820475
	MIL- LeverDO	-	820476
	MIL- CableFixed	-	820477
	MIL- CableDO	-	820478

## Accessories

	Product	Frame	Cat Ref.
	Key-Lock1L + 1k	-	820479
	Key-Lock2L + 1k	-	820480
	Key-Lock3L + 1k	-	820481
	Key-Lock3L + 2k	-	820482
	Key-Lock5L + 3k	-	820483

	Product	Frame	Cat Ref.
	Door interlock B1,B2	-	820485

	Product	Frame	Cat Ref.
	Door frame fixed B1	-	820486
	Door frame fixed B2	-	820487
	Door frame D/O B1	-	820488
	Door frame D/O B2	-	820489

	Product	Frame	Cat Ref.
	Dust cover B1,B2	-	820490

	Product	Frame	Cat Ref.
	Power module 415V B1,B2	-	820491
	Power module 230V B1,B2	-	820492